

L:
 CBL-HFPD3SAB5CSS-1m 1000mm±20mm
 CBL-HFPD3SAB5CSS-2m 2000mm±20mm
 CBL-HFPD3SAB5CSS-3m 3000mm±20mm

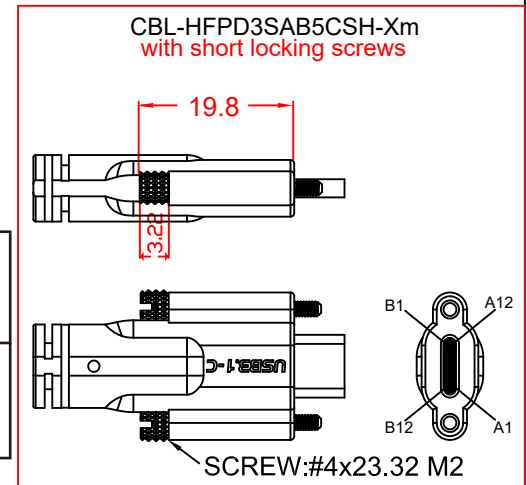
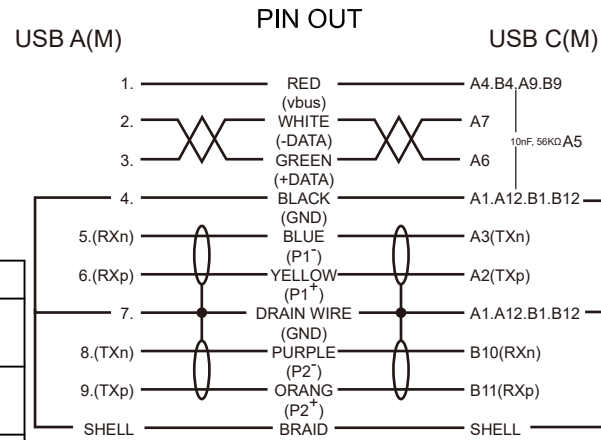

No	MATERIALS LIST:
1.	CABLE: 3 x (2 x 28 AWG)ST + 2 x 26 AWG O.D.:.6.1mm COLOR:RED LILAC
2.	CONNECTOR:USB 3.0 A/M, 9P, BLUE INSULATOR SOLDER TYPE, NICKEL PLATED SHELL
3.	CONNECTOR:USB 3.1 TYPE-C, MALE, NICKEL PLATED SHELL
4.	PVC MOLDED HOUSING, BLACK COLOR
5.	SCREW:#4x33 M2
6.	SCREW:#4x34.5 M2

Jargy part no.	Client part no.	Approved	SCALE	UNIT
CBL-HFPD3SAB5CSS-xm				mm
Drawing Name		Drawn	Date	REV.
USB 3.1 GEN 1 A to C Cable M/M				1.0

Mobile Computing JARGY

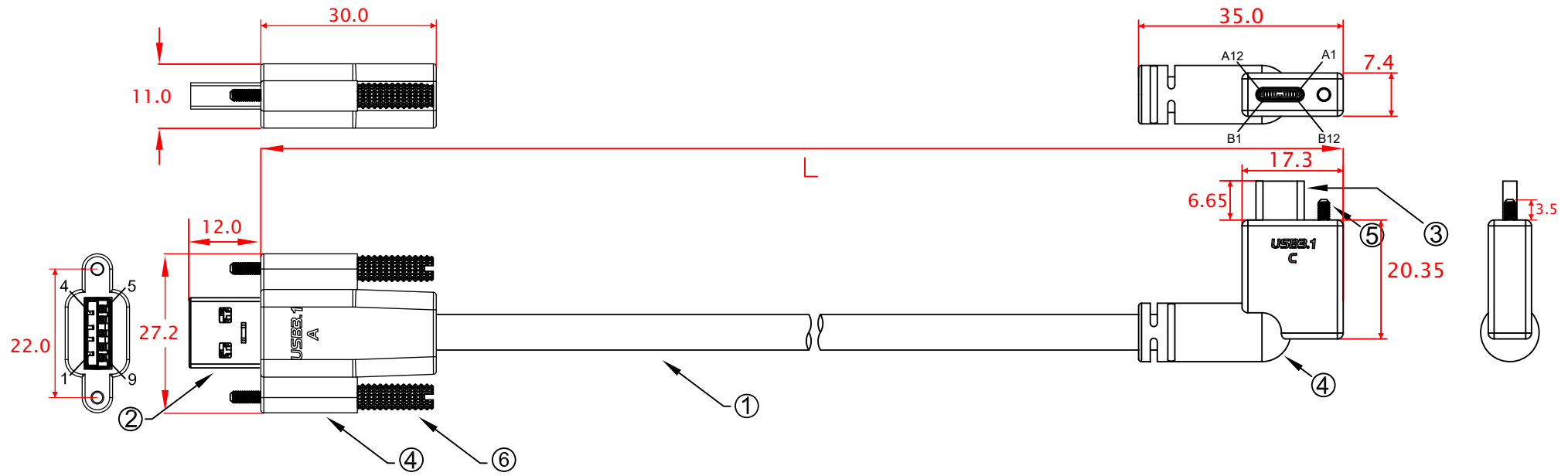

L:
 CBL-HFPD3SAB5CSH-1mLRA 1000mm±20mm
 CBL-HFPD3SAB5CSH-2mLRA 2000mm±20mm
 CBL-HFPD3SAB5CSH-3mLRA 3000mm±20mm

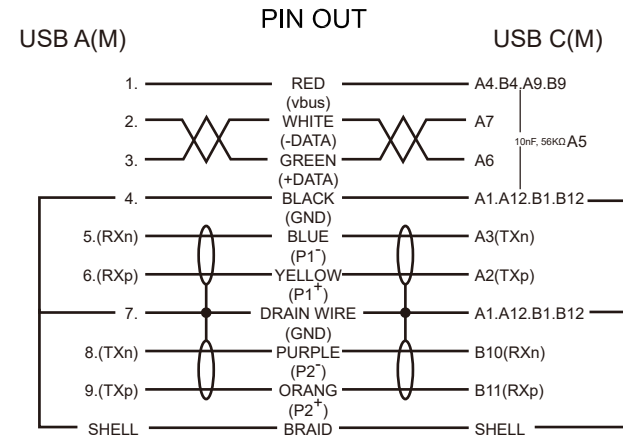

No	MATERIALS LIST:
1.	CABLE: 3 x (2 x 28 AWG)ST + 2 x 26 AWG O.D.:.6.1mm COLOR:RED LILAC
2.	CONNECTOR:USB 3.0 A/M, 9P, BLUE INSULATOR SOLDER TYPE, NICKEL PLATED SHELL
3.	CONNECTOR:USB 3.1 TYPE-C, MALE, NICKEL PLATED SHELL
4.	PVC MOLDED HOUSING, BLACK COLOR
5.	SCREW:#4x23.32 M2
6.	SCREW:#4x34.5 M2

Jargy part no.	Client part no.	Approved	SCALE	UNIT
CBL-HFPD3SAB5CSH-xmLRA				mm
Drawing Name		Drawn	Date	REV.
USB 3.1 GEN 1 A to C Cable M/M				1.0

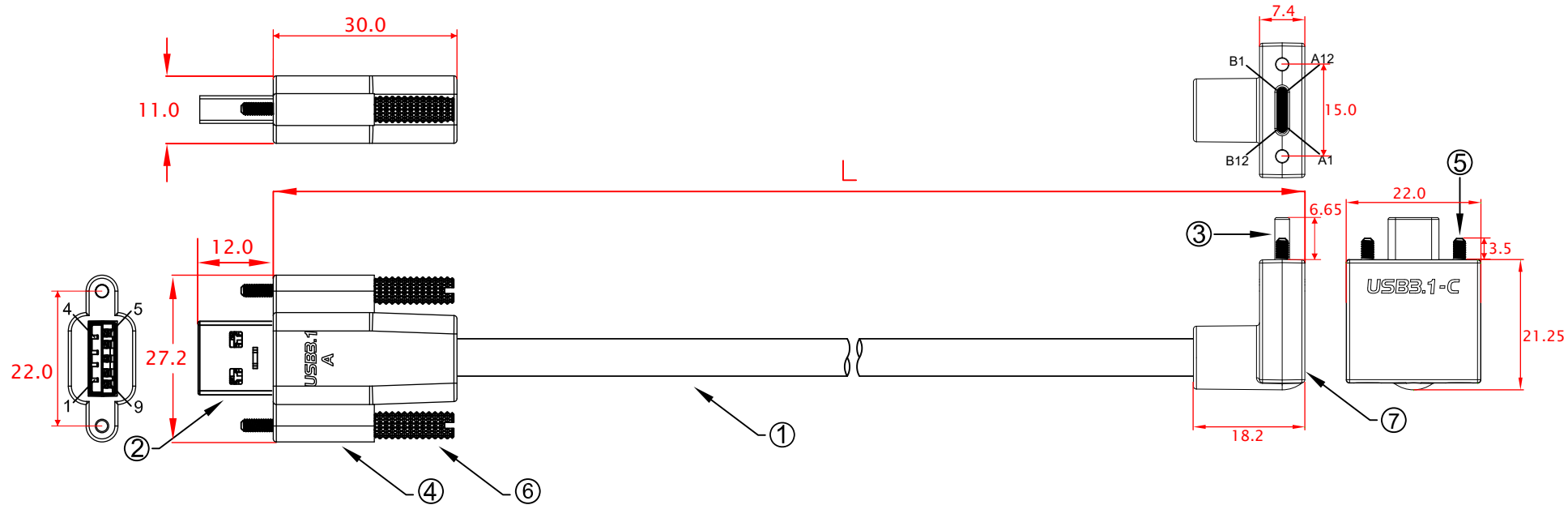

- L:
 CBL-HFPD3SAB5CSH-1mUDA 1000mm±20mm
 CBL-HFPD3SAB5CSH-2mUDA 2000mm±20mm
 CBL-HFPD3SAB5CSH-3mUDA 3000mm±20mm

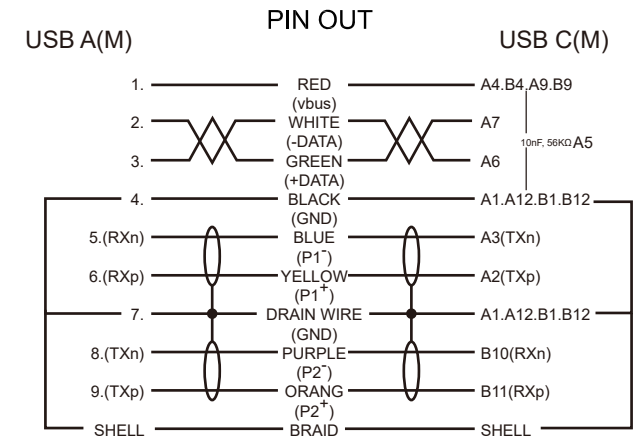

No	MATERIALS LIST:
1.	CABLE: 3 x (2 x 28 AWG)ST + 2 x 26 AWG O.D.:.6.1mm COLOR:RED LILAC
2.	CONNECTOR:USB 3.0 A/M, 9P, BLUE INSULATOR SOLDER TYPE, NICKEL PLATED SHELL
3.	CONNECTOR:USB 3.1 TYPE-C, MALE, NICKEL PLATED SHELL
4.	PVC MOLDED HOUSING, BLACK COLOR
5.	SCREW:#4x23.32 M2
6.	SCREW:#4x34.5 M2
7.	ABS ASSEMBLY HOUSING, BLACK COLOR

Jargy part no.	Client part no.	Approved	SCALE	UNIT
CBL-HFPD3SAB5CSH-xmUDA				mm
Drawing Name		Drawn	Date	REV.
USB 3.1 GEN 1 A to C Cable M/M				1.0